

Tank Weighing Assembly



FEATURES

- Rated capacities of 50 to 2500 pounds
- Steel or stainless steel construction
- Low profile design
- Trade certified for NTEP Class III: 10000 divisions and Class III: 5000 divisions available in 1000 to 2500 pounds
- Mounts directly to floor or structural support
- Unique neoprene isolation mount accommodates shock/vibration, thermal expansion and load misalignment
- *Sensorgage™* sealed to IP65/67 standards
- Factory Mutual System Approved for Classes I, II, III; Divisions 1 and 2; Groups A through G. Also, non-incendive ratings (No barriers!)

DESCRIPTION

The 65059-TWA is low to mid capacity alloy steel weighing assembly.

This product simply and easily converts any industrial tank, table, or platform into a high accuracy scale. The 65059 weighing assembly is shipped pre-assembled and ready to bolt between the support legs of a platform, tank, or container and the concrete floor. The top pad of this assembly is constructed from a special stiff neoprene rubber. This pad further simplifies installation by creating a self-leveling system that eliminates the shimming process of the installation. This neoprene pad further benefits the user by

creating a vibration dampening effect that helps protect and isolate the load cell. The load cell is available in both nickel plated and stainless steel construction and sealed to IP67 standards, assuring reliability in industrial and wash down applications. The assembly is available only with zinc plating for corrosion resistance.

This weighing assembly is rated intrinsically safe by the Factory Mutual System (FM); making it suitable for use in potentially explosive environments. This weighing assembly is certified for Legal For Trade applications by both American NTEP and International OIML standards.

APPLICATIONS

- Tank, bin and hopper weighing
- Batching, blending and mixing
- Low capacity weighing

OUTLINE DIMENSIONS in inches

50 - 250lbs

50 - 250lbs

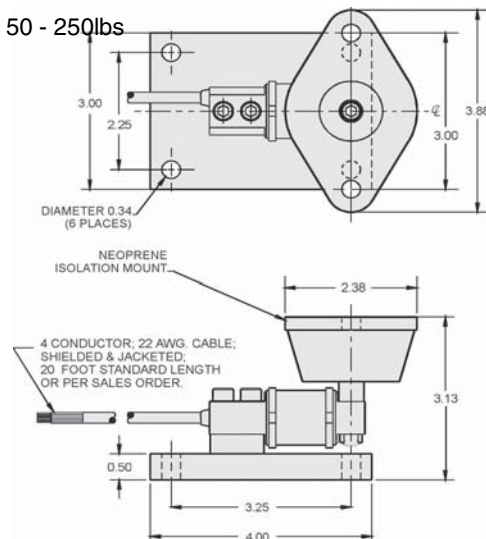

500lbs

500lbs

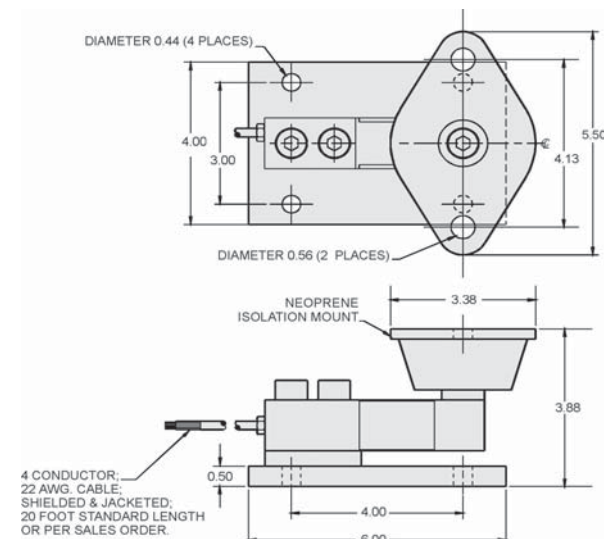

OUTLINE DIMENSIONS in inches

1Klbs

1.5K, 2K, 2.5K

1Klbs

1.5K, 2K, 2.5K

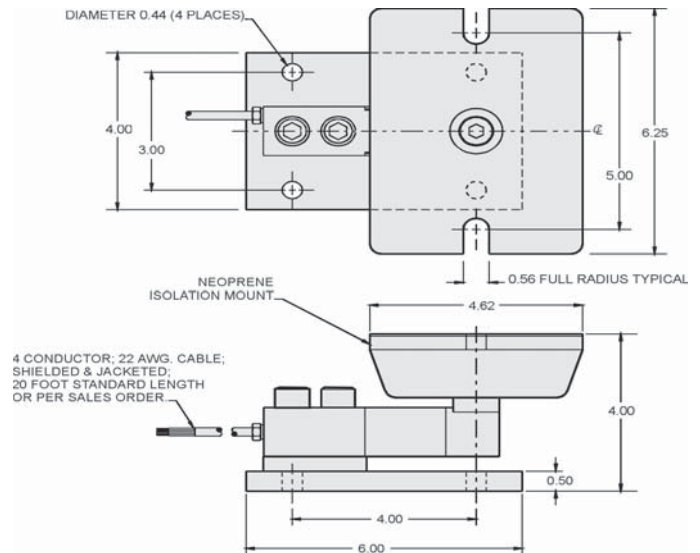
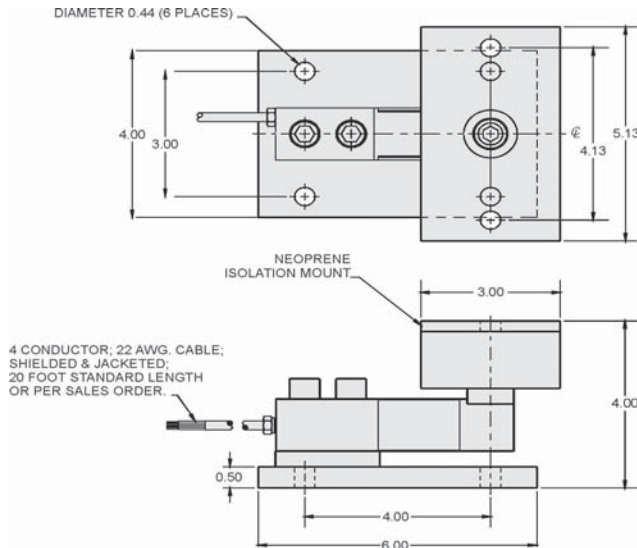

TYPICAL INSTALLATION

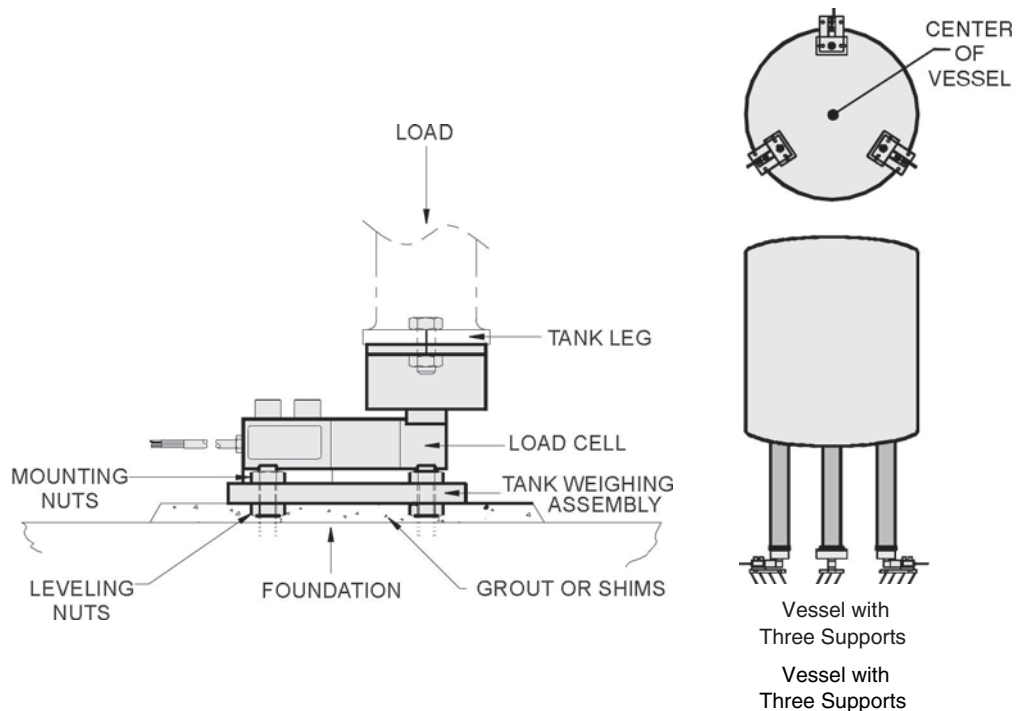

SPECIFICATIONS

| PARAMETER | VALUE | | | UNIT |
|-----------------------------------|--------------------------------------------|----------------------------|----------|-------------------|
| Rated capacity-R.C. (E_{max}) | 50, 75, 100, 150, 250, 500, 1K, 1.5K, 2.5K | | | lbs |
| NTEP/OIML Accuracy class | NTEP IIIIL | Standard | OIML R60 | |
| Maximum no. of intervals (n) | 10000 | | 3000* | |
| $Y = E_{max}/V_{min}$ | NTEP cert. 86-044A2 | | 6250 | Maximum available |
| Rated output-R.O. | 3.0 | | | mV/V |
| Rated output tolerance | 0.25 | | | ±% mV/V |
| Zero balance | 1.0 | | | ±% FSO |
| Combined error | 0.02 | 0.03 | 0.02 | ±% FSO |
| Non-repeatability | 0.01 | 0.01 | 0.01 | ±% FSO |
| Creep error (30 minutes) | 0.03 | 0.03 | 0.017 | ±% FSO |
| Temperature effect on zero | 0.0010 | 0.0015 | 0.0010 | ±% of load/°F |
| Temperature effect on output | 0.0008 | 0.0008 | 0.0007 | ±% of load/°F |
| Compensated temperature range | 14 to 104 (-10 to 40) | | | °F (°C) |
| Operating temperature range | 0 to 150 (-18 to 65) | | | °F (°C) |
| Storage temperature range | -60 to 185 (-50 to 85) | | | °F (°C) |
| Maximum safe central overload | 150 | | | % of R.C. |
| Ultimate central overload | 300 | | | % of R.C. |
| Excitation, recommended | 10 | | | Vdc or Vac rms |
| Excitation, maximum | 15 | | | Vdc or Vac rms |
| Input impedance | Capacities 50-250lbs - 380-450 | Cap. 500-2500lbs - 343-357 | | Ω |
| Output impedance | Capacities 50-250lbs - 349-355 | Cap. 500-2500lbs - 349-355 | | Ω |
| Insulation resistance at 50VDC | >1000 | | | MΩ |
| Material load cell | Nickel plated alloy tool steel** | | | |
| Material assembly | Zinc plated steel | | | |
| Environmental protection | IP67 | | | |
| Recommended torque | All capacities up to 2500lbs - 136 | | | N*m |

* OIML approval 1-2.5Klbs only

** Stainless steel available

FSO - Full Scale Output

Disclaimer

All product specifications and data are subject to change without notice.

Vishay Precision Group, Inc., its affiliates, agents, and employees, and all persons acting on its or their behalf (collectively, "Vishay Precision Group"), disclaim any and all liability for any errors, inaccuracies or incompleteness contained herein or in any other disclosure relating to any product.

Vishay Precision Group disclaims any and all liability arising out of the use or application of any product described herein or of any information provided herein to the maximum extent permitted by law. The product specifications do not expand or otherwise modify Vishay Precision Group's terms and conditions of purchase, including but not limited to the warranty expressed therein, which apply to these products.

No license, express or implied, by estoppel or otherwise, to any intellectual property rights is granted by this document or by any conduct of Vishay Precision Group.

The products shown herein are not designed for use in medical, life-saving, or life-sustaining applications unless otherwise expressly indicated. Customers using or selling Vishay Precision Group products not expressly indicated for use in such applications do so entirely at their own risk and agree to fully indemnify Vishay Precision Group for any damages arising or resulting from such use or sale. Please contact authorized Vishay Precision Group personnel to obtain written terms and conditions regarding products designed for such applications.

Product names and markings noted herein may be trademarks of their respective owners.